

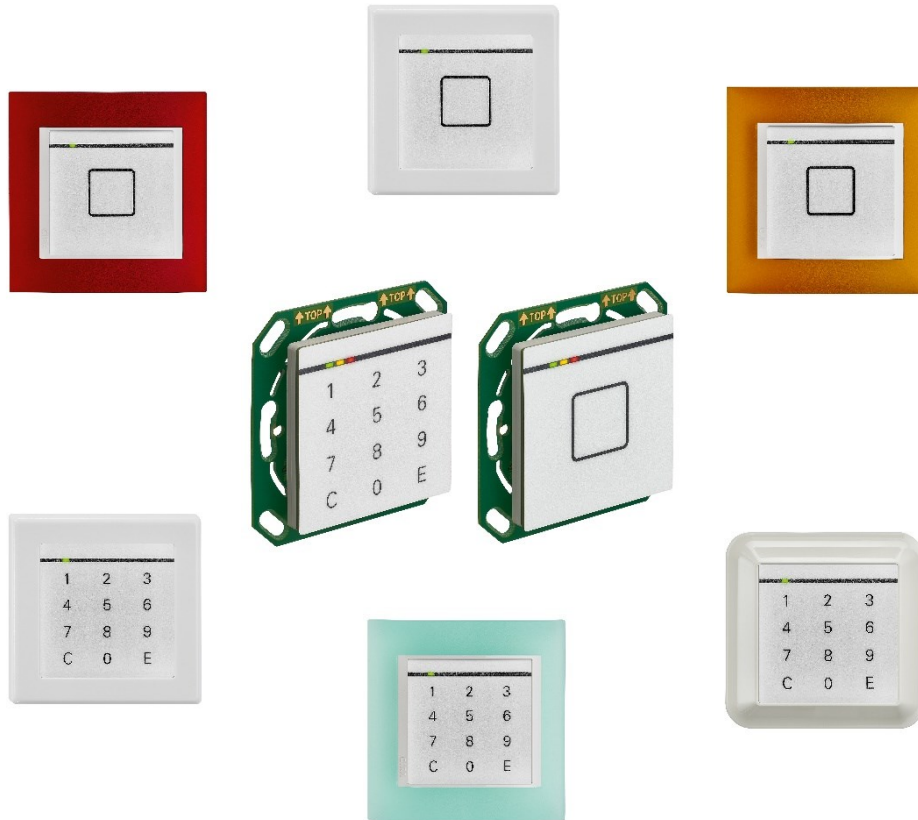

Family datasheet RELINO reader module

RELINO-B



-customized modifications possible-

Product designation

Variant	RFID Technology
RELINO-B-1550-A	<p>Multi-ISO reader (Basis LEGIC SM-6300)</p> <ul style="list-style-type: none"> ▪ LEGIC prime / advant ▪ Mifare classic / DESFire / EV1 / EV2 ▪ ISO 14443 A+B / ISO 15693 ▪ INSIDE secure ▪ Sony FeliCa subset (NFC Forum Type 3 Tag) ▪ ST SR Series <p><i>Note: LEGIC data carriers cannot be initialized!</i></p> <p>Bluetooth Smart:</p> <ul style="list-style-type: none"> ▪ V5.0 BLE (Bluetooth Low Energy) 

Family datasheet RELINO reader module

Interface

- RS 485 (A, B) **not** electrically isolated
 - Address setting via DIP switch
 - connectable bus terminating resistor (also via DIP switch)
- and
- „Magstripe“ Clock/Data
or
„Wiegand“ D0/D1

Fields of application

- Access control
- Time and attendance
- Data collection
- Parking systems, alarm systems
- General user identification

Special features

- Bluetooth® SIG certification (please see note in chapter „general information“ on the last page)
- Can be integrated into all branded switch programs with a 55 x 55 mm cut-out
- Antenna switchable
plastic frame / metal frame
- Sabotage monitoring possible
- RFID, Bluetooth® and Secure Element in one reader
- Supports Mobile Access by LEGIC Neon Files
- Connection type: screw plug-in terminal 9 pol.
- Signal elements
 - 3 LEDs, green, yellow, red
 - 1 piezo buzzer

Firmware / Software protocols

- phg_crypt
- „Magstripe“ Clock/Data format track 1 or 2 (configurable)
- „Wiegand“ D0/D1 format 26 Bit or 56 Bit (configurable)
- OSDP
- Modbus
- Customization possible



Information about the support of possible standard ISO transponders for the various software protocols is available on request.

Technical Data

Product designation	Nominal voltage [V _{DC}]	Nominal power [W]	Temperature ranges [°C]		dimensions [mm]	weight [g]
			storage	operation		
RELINO-B-1550-A	8 ... 30	Typ.: 0,5 Max.: 1,90	- 30 ... +70	-25 ... +60	70 x 70 x 26,1 (see below)	45

Dimensions:

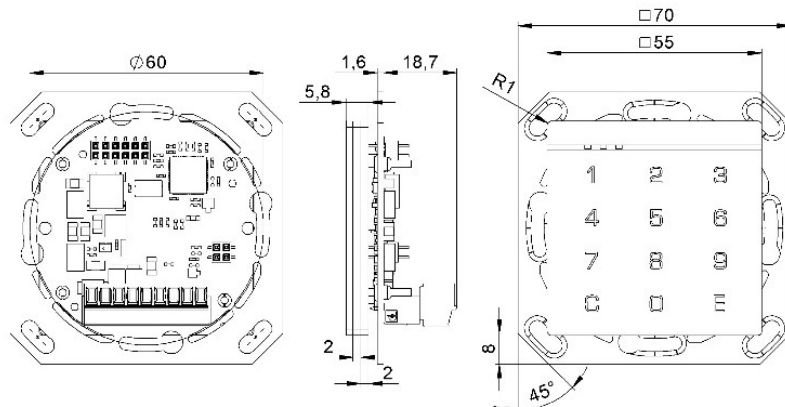

Supported transponder media



The support of the media named in the table below, generally depend on the variant or reading technology (hardware platform) as well as the firmware of each reader module.

Compatibility Transponders / Hardwareplattform LEGIC SM-6300		
RF standard	Supported LEGIC transponders	Supported third-party transponders **
LEGIC RF standard	MIM22, MIM256, MIM1024, CTC4096-MP410	
ISO 14443 A (also NFC Forum Type 2/4A Tag *)	ATC2048-MP110, ATC4096-MP311, CTC4096-MP410, AFS4096-JP11, CTC4096-MM410	ISO 14443 part 3/4 compliant: e.g. Infineon SLE, SmartMX Integrated support of MIFARE Ultralight, MIFARE Classic, MIFARE Plus and MIFARE DESFire NFC peer-to-peer target
ISO 14443 B *** (also NFC Forum Type 4B Tag *)		ISO 14443 part 4 compliant: e.g. InfineonSLE
ISO 15693 (also ISO 18000-3 mode 1)	ATC256-MV410, ATC1024-MV110, ATC1024-MV010, CTC4096-MM410	Selected types: e.g. EM 4035, Infineon SRF55VxxP, Tag-It HFI
INSIDE Secure (UID only)		INSIDE Secure compliant
SONY FeliCa subset (NFC Forum Type 3 Tag *)		SONY FeliCa **** NFC peer-to-peer target
<p>* Passive mode, initiator</p> <p>** Access with transparent mode (dedicated commands for MIFARE transponders)</p> <p>*** If ISO 14443 B (2001) transponders are used, only one transponder is allowed in the RF field. This restriction does not apply to ISO 14443 B (2008) transponders.</p> <p>**** The SONY FeliCa protocol is supported according to ISO 18092 (6 byte preamble). Older FeliCa cards with a shorter preamble are not supported.</p>		

Source: LEGIC Ident Systems

Attention:

Recommendation when using smart card chips for LEGIC „card-in-card“ solutions



Before use or planned use, a suitability and functional test of the corresponding medium should be carried out.

Detailed information about the procedure is available on request.

Family datasheet RELINO reader module



If required, we offer support with the transponder media analysis as well as the suitability and functional test. Reading ranges can vary depending on the installation situation and switch position on the RELINO front board (K or M).

Functionally tested transponders	
Transponder type	RELINO-B-1550-A Basis LEGIC SM-6300
LEGIC MIM 256	X
LEGIC MIM 1024	X
LEGIC ATC2048-MP110 (ISO 14443A)	X
LEGIC ATC4096-MP310 (ISO 14443A)	
LEGIC ATC4096-MP311 (ISO 14443A)	X
LEGIC AFS4096-JP10/11 (ISO 14443A)	X
LEGIC ATC256-MV410 (ISO 15693)	X
LEGIC ATC1024-MV110 (ISO 15693)	X
LEGIC ATC1024-MV010 (ISO 15693)	X
LEGIC CTC4096-MP410 (prime Zugriff)	X
LEGIC CTC4096-MP410 (ISO14443 Zugriff)	X
LEGIC CTC4096-MM410 (prime Zugriff)	X
LEGIC CTC4096-MM410 (ISO14443 Zugriff)	X
LEGIC CTC4096-MM410 (ISO15693 Zugriff)	X
MIFARE Classic 1k, 4k	X
MIFARE DESFire EV1 / EV2	X

Pin assignment terminal ST3

ST 3

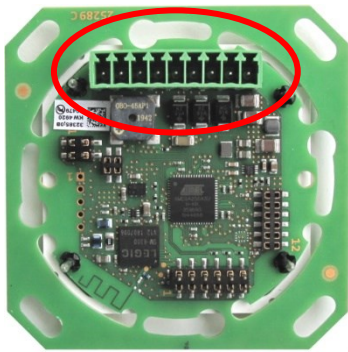

rear module without connection terminal

Pin No.	Function	description
1	Output 1 Open Collector max. 10 mA	Function depends on the firmware. Detailed information is provided to each reader.
2	Output 2 Open Collector max. 10 mA	
3	Input1 (Active Low)	
4	Input 2 (Active Low)	
5	Input 3 (Active Low)	
6	Data "A"	Interface RS485
7	Data "B"	
8	+Ub (8 to 30 V/DC)	External power supply
9	GND	

Terminal specification: Lift system / connection iameter 0.4 – 1.4 mm / stripping length 5 mm

Slot for 1 plug-in module

To connect the controller board. Depending on the plug-in module used, a correspondingly suitable reader firmware is required.

Optionally, on of those modules listed can be plugged into the socket strip marked in red. The following plug-on modules are available:

- Südmetall radio lock
- Relay 1 Tool
- RS 232
- SAM

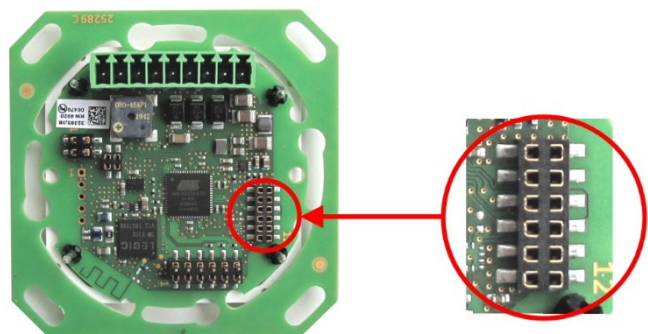

If you have further questions, please consult us for advice.

Family datasheet RELINO reader module

Detach the front board from the controller board

For the setting options described below, it is necessary to detach the front board from the controller board. The front board can be carefully removed from the controller board in order to select the desired antenna tuning and DIP switch setting (see following chapters)

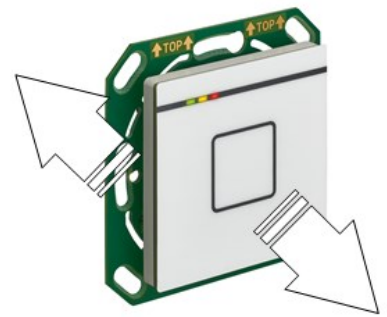

Function DIP switch

DIP-switch (8 times)

DIP-switch (8 times, S1 to S8)		Function
S1 - S7		Depends on the firmware e.g. setting of the reader address
S8	OFF	RS485 interface no bus terminating resistor
	ON	RS485 interface 120 Ohm bus terminating resistor
 The appropriate connection diagram is enclosed with every reader and also includes the DIP switch settings.		

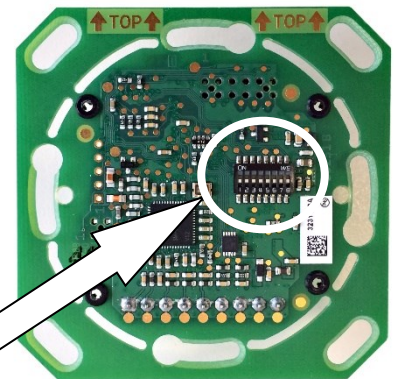

Function slide switch K < > M

Depending on the installation environment, the respective antenna for plastic or metal frames can be set on the front panel (using a miniature slide switch).

Recommendation:
Position „K“: when using plastic frames.
Position „M“: when using metal frames.

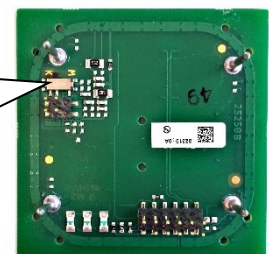
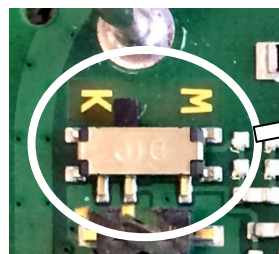

Installation

- 1.) Plug the wired connector into the controller board



- 2.) Screw the controller board to the flush mounting box and align horizontally mounting schrauben und waagrecht ausrichten

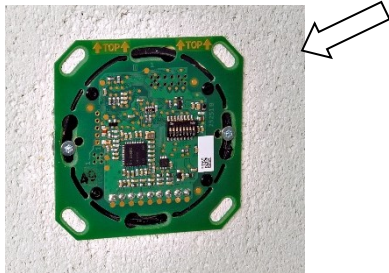

Attention:
Note TOP marking



The suitable connection plan is enclosed to the reader.

- 3.) By using an additional distance frame the insertion depth of the front panel in to the switch programm frame is adjustable

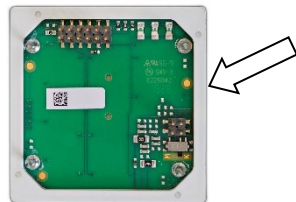

- 4.) Positioning and holding the switch program frame at the wall



- 5.) Front panel exactly positioning so the plug-in connector pins and the locking pins match properly with the holes on the controller board. As following step the front panel carefully push down in the direction to the controller board



- 6.) The front panel carefully push down up to there is completely in the frame imersed and this frame fits tightly on the wall.

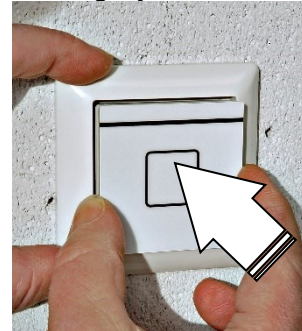

Disassembly

Recommendation:



Switch off power supply (voltage supply for the reader is disconnected)

Carefully insert a screwdriver or similar between the frame and wall and the clamping by uniformly sided pry loose slowly.

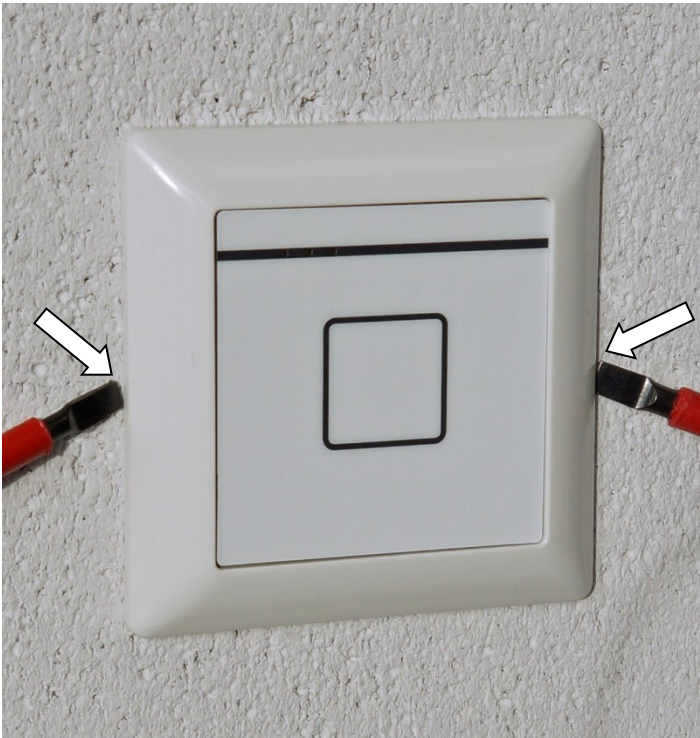

After the frame is a bit loose from the wall, grasp the frame with your fingers and pull it forward, so the the plug-in connector pins and the locking pins are separated from the controller board.

General information

Note on the use of Bluetooth brands on branding products

Only Bluetooth SIG Inc. (Bluetooth Special Interest Group) members may use the "Bluetooth trademarks" (text and logo) as agreed in the Bluetooth Trademark License Agreement (BTLA). If the brands are used in conjunction with a product, that product must have gone through and completed the Bluetooth qualification process.

If a company markets a phg-certified device with BLE function under its own name and logo (so-called branding), it must register or list this at the Bluetooth SIG Inc. However, an "adopter membership" must be applied for in advance.

When listing, a reference must be made to the phg listing. It is best to use BQC (Bluetooth Qualification Consultants). These can be found on the Bluetooth website (<https://www.bluetooth.com/develop-with-bluetooth/qualification-listing/qualification-consultants/>).

For branding with the Bluetooth label or using the designation "Bluetooth" the "Bluetooth Brand Guide.pdf" must be used. Available on the Bluetooth website (<https://www.bluetooth.com/de/develop-with-bluetooth/marketing-branding/>).

Influences (reduction) of the reading distance

An influence of the reading distance can have more reasons.

This is a list of facts that reduce the reading distance:

- Shielding the data carrier by metal materials, e.g. EC card in the wallet, key tag on a bunch of keys
- No optimum coupling, i.e. the antenna surface of the data carrier is vertical (90°) to the reader's antenna surface
- Data carrier itself
 - key tag (small active antenna surface)
 - poor resonance of the data carrier (IC card / key tag)
 - combined ID card (e.g. LEGIC® / inductive, mifare/inductive, etc.)
- Metal in the "active" surface of the HF field. The transmitting energy is reduced. This point is mainly relevant, when the reader components are integrated in metal cover plates (including metal pillars etc.).

Conformity statement

This product complies to the common legal requirements if used according to regulations. We provide you the EU declaration of conformity on demand.

Care and cleaning instruction

The use of hard or sharp objects (rings, fingernails etc.) can cause scratches and damage the device.

Wipe the device with a soft lint-free cloth, or one that has been lightly dampened with water.

The use of caustic liquids such as benzene, thinners, alcohol, solvents, or any kind of abrasive cleaners will lead to surface deterioration and damage.

Waste Disposal



This product **must not** be disposed in normal household waste!